



COMPANY BROCHURE

WE DEAL IN

ALUMINIUM PROFILE | ALUMINIUM PROFILE ACCESSORIES | LINEAR MOTION PRODUCTS | HARD CHROME & INDUCTION CHROME RODS | ASSEMBLY TABLES | ESD SAFE WORKSTATION

MANUFACTURER | WHOLESALER | TRADER

ABOUT US

Established in the year 2019, Crystal Technology is a distinguished Manufacturer, Wholesaler and Trader of aluminium profile, accessories, linear motion products, hard chrome rods, assembly tables, ESD safe workbenches, etc.

Immensely acclaimed in the industry owing to their preciseness, these are presented by us in standard forms to our clients. These are inspected sternly to retain their optimum quality.

VISION

To be the premier industrial supplier, revolutionizing industries with cutting-edge solutions, unmatched service, and sustainable practices, driving global progress and prosperity.

OUR PRODUCTS

1 Aluminium Profiles

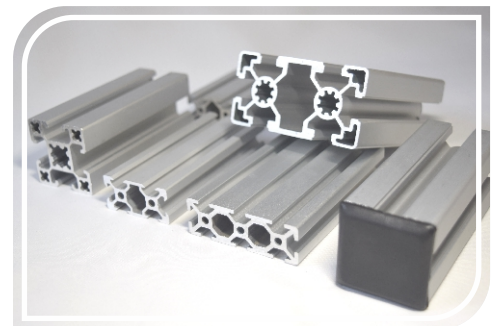
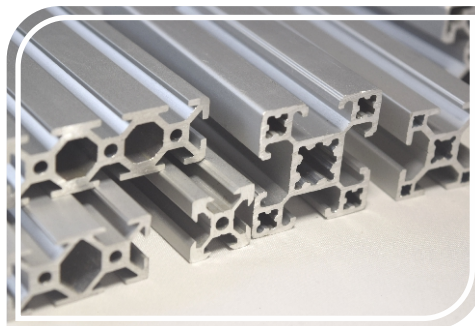
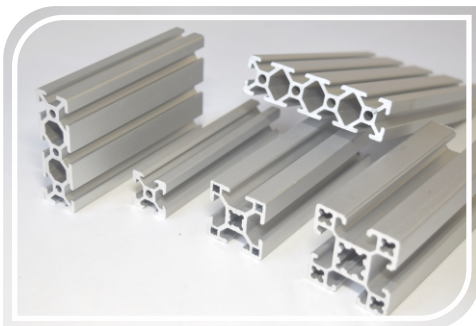

High-quality aluminum extrusion profiles offering versatile and lightweight solutions for various industries. Precision-engineered for durability and customization, these profiles empower innovation in diverse applications. Available in all standard dimensions.

2 Aluminium Profile Accessories

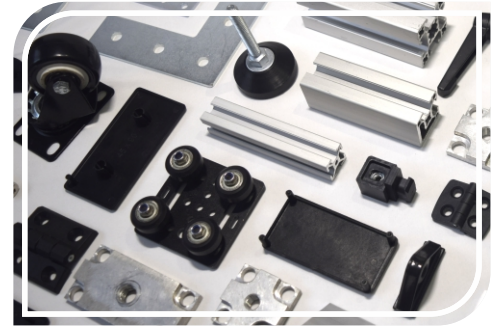
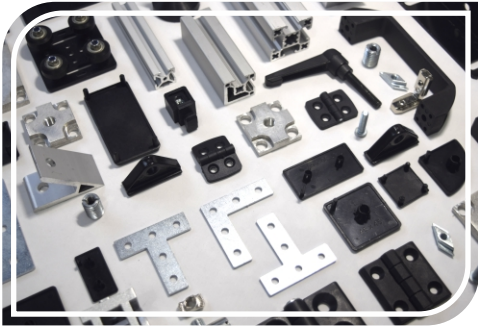

Our aluminum profiles accessories complement your projects seamlessly, ensuring sturdy and flexible assembly solutions. These high-quality components enhance structural integrity and adaptability for diverse applications.

3 Linear Motion Products

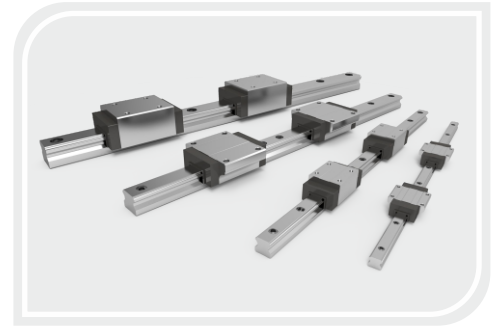
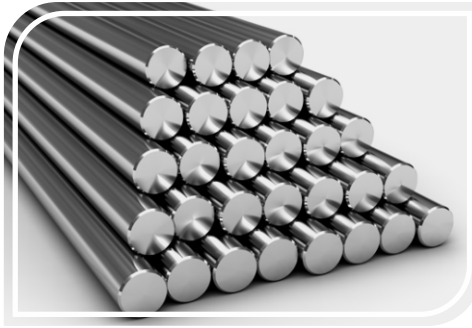
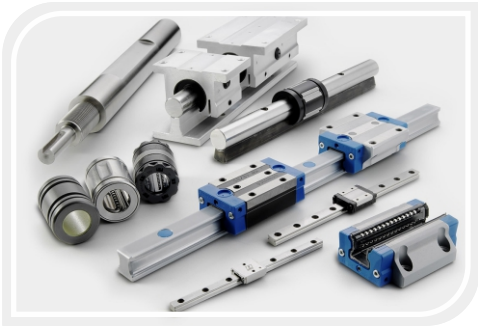

Precision-engineered linear motion products for efficient and smooth movement in industrial automation and robotics, enhancing accuracy and productivity.

➤ *Following are the available linear motion products.*

Hard chrome Induction Rods | Linear Bush Bearing | Housing with Bearing | Linear Shaft With Support | Linear Shaft End Support | Linear Guideway | Miniature Linear Guideway | Rolled Ball Screw & Nut | Ball Screw Support unit

4 Assembly and ESD Safe Workbenches/ Tables



Our customized assembly tables are tailored to optimize workflow with precision, versatility, and efficiency. They provide the ideal workspace for streamlined assembly processes, boosting productivity."

GET IN TOUCH



91681 69106, 9552 828 787



mrkt.crystaltech@gmail.com
crystaltech13@gmail.com



Yogita Heights Benkar Mala,
SR No 8/3, Ground floor, Near
Yogesh Washing Centre Pari
Company Road, Dhayari,
Pune - 41

Scan this QR code to
download our product
catalogue



**CRYSTAL
TECHNOLOGY**

